

# Agreement in Standard Arabic VSO and SVO Word Orders: A Feature-based Inheritance Approach

Abdul-Hafeed Ali Fasih

Department of English, Ibb University, Yemen;  
Department of English, Najran University, Saudi Arabia

**Abstract**—This study investigates agreement in VSO and SVO word orders in Standard Arabic (henceforth, SA), shows how VSO and SVO are derived in the syntax, and proposes an alternative analysis based on Chomsky' (2005) feature-based-inheritance approach, which seeks to provide a unified account on the subject. The objective is to explore the interaction between the SA data and Chomsky's feature inheritance analysis. It shows that whether the subject (i.e. the goal with which C agrees) in Spec-v\*P in VSO order or in Spec-TopP (=Topic Phrase) in SVO order, the Agree relation can apply and all unvalued uninterpretable features are valued and deleted by matching them with their valued interpretable counterparts. Furthermore, I argue that since the edge feature of the head C of the CP phase is inherited by the Top head, the topicalised elements in Standard Arabic are raised from lower positions to Spec-TopP in SVO order, not the specifier of CP, as assumed in Chomsky (2005). Besides, the paper points out that in SA the features of T in VSO order and the features of T and Top in SVO order are inherited from C, the head of the CP phase. It also adopts Rizzi's (1997) Spilt-CP analysis and proposes a modification of Chomsky's (2005) clause structure in order to account for the position of the topicalised subject in SVO in SA.

**Index Terms**—agreement, feature inheritance, agree, edge feature, unvalued uninterpretable features, TopP, phase

## I. INTRODUCTION

The agreement and word order phenomenon in Standard Arabic (SA) has been the focus of discussion and analysis over the last three decades by the Arab and Western linguists. What is interesting in SA is that there are two dominant word orders which are commonly used in formal settings and daily life conversations: VSO and SVO. In this study I concern myself with agreement in VSO and SVO orders in SA: in the former (i.e. VSO) the subject immediately follows the verb while in the latter the subject (if the preverbal subject NP proves to be a subject) precedes the verb. It has been observed in SA that agreement patterns on the verb morphology are visibly associated with these word orders (Mohammad, 1990, 2000; Aoun et al, 1994; Fassi Fehri, 2005; Benmamoun, 2000a; and Fasih, 2012, 2015).

Furthermore, almost all agreement analyses in SA have shown that agreement in VSO and SVO orders depends on the subject position in relation to that of the verb. In SVO order full agreement exists between the preverbal subject and the verb while partial agreement is obtained between the postverbal subject and the verb in VSO order (Mohammad, 1990; Bahloul and Harbert, 1992; Fassi Fehri, 1993, 2004; Bolotin, 1995; Shlonsky, 1997; Benmamoun, 2000b; Harbert and Bahloul, 2002; and Benmamoun and Lorimor, 2006). Moreover, it can be observed in Arabic agreement literature that subject-verb agreement is commonly known for having an agreement asymmetry which is sensitive to word order variation. There are also other languages in the world which have agreement asymmetries and exhibit word order variation, as seen in Russian (Corbett, 2006), and French and Italian (Frank, Lassi, Frauenfelder and Rizzi, 2006).

This study seeks to explore agreement in VSO and SVO orders, show how VSO and SVO orders are derived morpho-syntactically in SA, and in turn propose an alternative minimalist analysis which provides a unified account on the subject under discussion. It adopts Chomsky's (2005) feature-based-inheritance approach which accounts neatly for the implicit questions raised in this work. It also adopts Rizzi's (1997) Spilt-CP analysis and suggests a modification of Chomsky's (2005) clause structure in order to account for the preverbal subject in SVO order in SA.

The topic of agreement in VSO and SVO orders in SA has been selected for study for the following reasons: (i) agreement in SA has recently been the focus of considerable discussion by Arab and Western scholars, who presented various attempts to analyze agreement patterns in SA within different approaches to syntactic analyses. However, their analyses did not offer a satisfactory account on the subject under investigation. (ii) There is a need to provide a unified account of agreement in VSO and SVO orders in SA within the latest version of Chomsky's (2005) feature inheritance framework, show how VSO and SVO orders are derived in minimalist syntax and how the Arabic data can interact with Chomsky's feature inheritance analysis. The objective is to offer an alternative account to the previous analyses on agreement and word order variation in SA.

The paper is organized as follows. Section 2 is a literature review on agreement and word order in SA; it reviews the pre-minimalist accounts and explores agreement in minimalist syntax. Section 3 offers an alternative analysis based on Chomsky's (2005) feature inheritance model. It also adopts Rizzi's (1997) Split-CP analysis and proposes a modification of Chomsky's (2005) clause structure to explain the preverbal topic in SVO in SA. Section 4 investigates derivational operations in SA syntax. Section 5 shows how VSO and SVO orders are derived in SA and explores partial and full agreement in VSO and SVO, respectively. Section 6 presents the conclusion of the study.

II. THEORETICAL BACKGROUND

A. Pre-minimalist Analyses on Agreement in SA

A closer look at the previous analyses on agreement in SA reveals that such accounts adopt Koopman and Sportiche's (1991) VP-Internal Subject Hypothesis which postulates that the postverbal subject originates in Spec-VP. On the other hand, the preverbal subject in VSO constructions moves from Spec-VP to Spec-TP; this movement is motivated by an EPP feature on T, as seen in (Aoun et la, 1994; Ouhallah, 1994; Mohammad, 1990, 2000; and Mahfoudhi, 2002, among others. In this section I review different accounts on agreement in SA. These accounts are based on the Government & Binding (GB) approach and the earlier version of the Minimalist Program (MP) framework.

A). **Mohammad's (1990) Null Expletive Hypothesis**

In Chomsky's (1981, 1986, and 1991) GB approach, subject-verb agreement and nominative Case assignment are associated with a Spec-head configuration. The development of the proposal has been seen in Kayne's (1989) discussion of past participle in Romance and witnessed some refinement in Pollock's (1989) Split INFL Hypothesis; the latter explores the layered structure of IP and proposes two AgrP projections (i.e. AgrsP and AgroP) in his influential work on tense and agreement.

Furthermore, building on Pollock's (1989) work, Mohammad (1990, 2000) revisits the analysis of agreement asymmetry in SA and proposes what he calls the 'null expletive hypothesis.' Mohammad claims that agreement is determined under Spec-head configuration. The verb which exhibits grammatical agreement is in the head position T, while an item which determines partial or full agreement on the verb is located in a Spec of TP. Mohammad assumes that partial agreement (i.e. gender agreement) in the unmarked VSO order in SA is obtained via a Spec-head relation between the head I (NFL) and a null expletive in its Spec. That is, in VSO sentences, partial agreement on the verb is the result of the relation between the verb in INFL and a third person singular expletive pronoun in Spec-TP. Hence, Mohammad's (1990, 2000) partial agreement can be derived in the following syntactic representation in (1).

1.

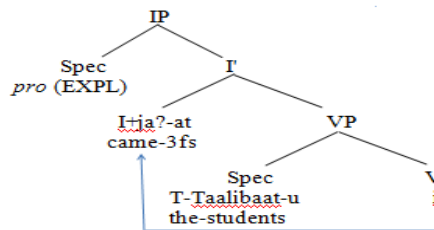

The representation in (1) illustrates how VSO order can be derived in SA, according to Mohammad (1990).

On the other hand, Mohammad argues that in SVO structures full agreement is determined by the preverbal noun phrase, i.e. the lexical subject in Spec-TP. Given this, Mohammad assumes that in SVO order in SA the verb and the subject are also in a Spec-head relation which results from movement of the subject DP from the VP-internal position to Spec-TP, thus deriving full agreement structure. This can be shown in (2) which can schematize the derivational process of SVO order in SA.

- 2a. ?al-?awlaad-u      waSal-uu  
       the-boys.nom.      arrived-3mp.  
       'The boys arrived.'
- b.

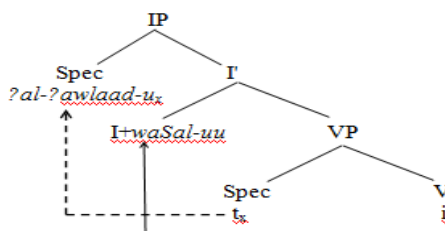

(2b) illustrates that the preverbal subject *?al-?awlaad-u* 'the boys' is in a Spec-head configuration with the verb in the head I(NFL), whereby full agreement between both the verb and its preverbal subject must be achieved.

It should, however, be stated that the null expletive analysis of Mohammad (1990) has some problems; two strong arguments are raised against it. The first argument is theoretical in the sense that the null expletive analysis fails to handle the problem of nominative Case assignment and show the properties of overt expletives in SA. The second argument is empirical; it comes from two different directions. The first one comes from Arabic (Aoun et al, 1994) and the second is cross-linguistically realized in Icelandic (Taraldsen, 1995). In addition, Aoun et al (1994) present a strong argument against the null expletive analysis based on an analysis of agreement patterns from Lebanese Arabic.

On the other hand, Fassi Fehri (1993) argues that the null expletive analysis fails to account for the full agreement pattern found in VSO sentences in Arabic varieties such as Moroccan Arabic (henceforth, MA) and Jordanian Arabic (henceforth, JA). Fassi Fehri's (1993) argument against the null expletive hypothesis stems from the fact that the expletive need not be third person singular since it can also be third person plural pronoun.

Furthermore, Bahloul and Harbert (1992) present a strong argument against the null expletive hypothesis and argue that it fails to account for the structures where the verb exhibits full agreement with the pronominal subject whether it is postverbal or preverbal.

#### **B). Benmamoun's (1992) Agreement Analysis**

In his analysis of agreement in SA, Benmamoun (1992) assumes that both full agreement and partial agreement occur in different configurations. That is, partial agreement in VSO order in SA takes place under government configurations, while full agreement in SVO occurs in a Spec-head configuration; the former agreement is achieved when the verb in the head T governs the subject, whereas the latter is achieved when the subject is located in Spec-TP.

#### **C). Fassi Fehri's (1993) Incorporation Analysis**

Fassi Fehri (1993) argues that the nominative pronominal bound forms can be taken to be real pronouns or inflectional markers. When a sentence in SA such as (3) below does not have an overt subject, the pronominal clitic is viewed as an incorporated pronoun.

3. sharib-uu                      al-Haleeb-a  
    drank.3m.they.nom        the.milk.acc  
    'They drank the milk.'

On the other hand, if the subject is an overt NP, the pronominal clitic is seen as a genuine marker. In an attempt to explain this phenomenon, Fassi Fehri (1993) suggests the AGR criterion below.

4. *AGR Criterion: rich AGR is licensed by an argumental NP in its Spec, and an argumental NP in Spec AGR is licensed by rich AGR. (Fassi Fehri, 1993, p. 34)*

#### **D). Aoun et al's (1994) Agreement Loss Account**

Aoun et al (1994) assume that full agreement between the subject and the verb is achieved in SVO and VSO word orders. They argue that full agreement in VSO sentences in SA is lost because of the movement of the verb from the head T to a higher functional head F of FP (Focus Phrase). According to Aoun et al (1994), loss agreement in number features in VSO order in SA is attributed to Aoun et al's distinction between number and gender features. They indicate that the head movement has to obtain number agreement.

### **B. Agreement and Minimalist Analysis**

The emergence of Chomsky's (1993) Minimalist Program (MP) led to a radical departure from the GB approach. The MP suggested an elimination of the asymmetry in the syntactic configuration in the attempt to provide a unified account for agreement and Case assignment cross-linguistically. Chomsky (1993) suggests not only a Spec-head framework to simplify the analysis of agreement and Case assignment but also calls for the deletion of the notion of government from the theory of grammar. On the other hand, in the attempt to refine the MP and improve the areas of weaknesses pointed out by syntacticians in the minimalist analyses, Chomsky (1993, 1995) proposes two-cycle syntax: an overt cycle, which deals with the Phonetic Form (PF), and a covert cycle, which deals with meaning and operations mapping to the Logical Form (LF). Chomsky indicates that licensing of agreement and Case features are assumed to cover either in overt or covert syntax; this depends on the "strength" or "weakness" of morpho-syntactic features. It can be observed that serious challenges faced the MP analysis. When the MP eliminated both the Spec-head relation and government while attempting to present a unified account of agreement and Case phenomena, it ended up with more unnecessary complications in natural language grammar. Because the AgrP was minimalistically suspect, Chomsky (1995) dispensed with it altogether from the theory of grammar for the reason that it was viewed as a mere set of uninterpretable  $\phi$ -features which demanded licensing in the course of the derivation in order to sustain convergence of the derivation at LF.

In their earlier minimalist analysis of agreement asymmetry in Arabic, Aoun and Benmamoun (1999) and Benmamoun (2000a) postulate a minimalist account which assumes that the merger of the verb and the subject in VSO constructions in SA takes place at the PF component. As a result, partial agreement realized in VSO sentences in SA is attributed to the PF merger of both the verb and the subject. However, there is a shortcoming in Benmamoun's analysis because it does not explain clearly why full agreement is achieved in VSO structures in the local varieties of Arabic such as Moroccan Arabic.

#### **A). Soltan's (2006) Null pro Analysis of Agreement in SA**

According to Soltan's (2006), the preverbal subject in SVO is base-generated in Spec of TP in order to satisfy an EPP feature on T. Soltan (2006) argues that the specifier position of vP is occupied by a null *pro* which is associated with the preverbal subject. Conversely, the head T in VSO sentences has no EPP feature. Hence, the subject originates and remains in situ in Spec-vP. Moreover, building on Chomsky's (2000, 2001) recent analysis on Agree, Soltan (2006) postulates that T in SA has three uninterpretable features: (i) T may appear with  $\phi$ -features. (ii) T has to have a separate gender feature (which Soltan calls CLASS feature). (iii) T may appear with an EPP feature. This entails that T in Arabic is always valued for gender but does not need to be valued for person and number, nor for a specifier. In his analysis of agreement in Arabic, Soltan discusses the derivation of SVO and VSO orders. Soltan (2006, p. 256) illustrates the structural representation of full agreement in VSO structures in (5) below.

5.

[CP C [TP DP T EPP/ $\phi$ /CLASS [v\*P *pro* v\* [VP]]]]

According to Soltan, T, which shows agreement with a *pro*, has to be a full T in order to meet the *pro* identification requirement advocated in Rizzi (1982).

However, in VSO order, only a gender/CLASS feature shows up on the verb. Given gender agreement, the Agree operation takes place between T and the postverbal lexical DP in Spec-v\*P, as demonstrated in (6).

6.

[CP C [TP T CLASS [v\*P DP v\* [VP]]]]

B). *Al-Horais' (2009) Analysis*

Al-Horais (2009) points out that Soltan's (2006) analysis of the null *pro* does not offer a unified account of agreement asymmetry in SA. In examining Soltan's analysis, two problems can be traced. In the first problem, Soltan assumes that agreement with a *pro* subject is only compatible with a full T ( $u\phi$ -features, gender and EPP features). The second problem which shows up with the null *pro* analysis is that Soltan assumes that the preverbal subject in SVO order is base-generated in Clitic Left Dislocation position and does not reach there via movement.

Moreover, in his minimalist analysis of agreement asymmetries in Arabic, Al-Horais (2009) adopts the theory of null subjects and agreement advocated in Holmberg (2008). According to Al-Horais (2009), this theory assumes that rich agreement results "from incorporation of a null subject pronoun in T as a direct result of Agree in the sense of Chomsky (2001)" (p. 1).

C). *Ouhalla's (2005) Account*

Ouhalla (2005) explores agreement features in Berber with some reference to some examples from SA. Ouhalla indicates that "the verbal feature reduces to [PERSON] and the nominal feature to [CLASS]" (p. 686). Ouhalla observes that agreement, viewed as a reflex of feature-matching and deletion, turns out to be a computational mechanism of categorization. Ouhalla (2005) indicates that agreement features come in "a (packaged) bundle is found in pronouns and categories that derive from them, such as verbal and nominal agreement inflection" (p. 693).

### III. ALTERNATIVE ANALYSIS

The study has reviewed a number of previous analyses on agreement and word order in SA and pointed out that they are not adoptable within Chomsky's (2005) feature inheritance model. I assume that the proposed feature-based-inheritance analysis can present a good alternative to the preceding null expletive hypothesis (Mohammad, 1990, 2000) and the null *pro* hypothesis (Soltan, 2006). Furthermore, the alternative analysis provides a neat account of agreement in SA than that presented in the agreement loss (Aoun et al, 1994 and Mahfoudhi, 2002) and MP merger of the verb and subject (Benmamoun, 2000a and Aoun and Benmamoun, 1999) because these accounts do not offer a satisfactory treatment when I compare them to the analysis in Chomsky's (2005) feature inheritance approach.

Moreover, the proposed analysis shows clearly that agreement asymmetry in SA disappears once I adopt Chomsky's (2005) feature inheritance framework which illustrates that agreement on the verb (as the result of the Agree relation) is achieved under the probe-goal relation. What is interesting in the proposed account is that agreement does not change when the goal moves or remains in situ. Besides, it accounts for the syntactic behavior of the preverbal subject in SVO order in SA; the preverbal subject moves from Spec-vP to Spec-TopP via TP to get topicalisation. The subject movement leaves behind a pronounceable copy which is seen as a resumptive pronoun. Before I present the alternative analysis I discuss first the recent developments in Chomsky's (2005) Agree model, phase theory and feature inheritance framework on the basis of which I base my proposed analysis on agreement in SA. Furthermore, the alternative analysis benefits from Rizzi's (1997) Split-CP analysis on the basis of which I suggest a modification of Chomsky's (2005) clause structure in order to account for the position of the preverbal subject in SVO in SA.

#### A. *Derivational Operations in Minimalist Syntax*

As illustrated above, Chomsky (2000, 2001, 2005) proposed three primitive operations (i.e. Merge, Move, and Agree) in his recent minimalist analysis of linguistic phenomena in natural language grammar. In what follows, I discuss the operation Agree because it is relevant to the discussion.

*The operation Agree*

Chomsky (2000) views the Agree operation as a feature-driven movement eliminated in favour of a long-distance agreement relation which matches the interpretable features with their uninterpretable ones. Chomsky emphasizes that the Agree operation provides not only all the feature-deletion results accomplished by the Move operation but also without moving items from their positions in the construction. This can provide support to Chomsky's argument that the Agree operation is more consistent with the Economy Principle of Chomsky (1995).

Moreover, Agree establishes a syntactic relation between two active elements which have matching unvalued features; it relates a Probe with a matching Goal. Both the Probe and Goal must be active; the former has to have unvalued features (i.e.  $\phi$ -features) which have to be valued by matching them with other valued features on the Goal. Similarly, being active, the Goal has to have an unvalued feature, in particular the Case feature which is the matching feature on the Probe. Since the Probe and the Goal are two agreeing heads, they must be in a specific configuration. That is, the Probe agrees with the closest Goal it c-commands. What results from the Agree relation here is that all unvalued uninterpretable features of the Probe and the Goal are valued and deleted.

In short, in the earlier MP analysis, Chomsky (1995, 2000) assumes that uninterpretable features trigger the operation Move. In a recent development of the MP, Chomsky (2005) introduces the operation Agree, thus Move is suppressed since it is not triggered by the necessity to value and delete uninterpretable features. When it occurs as a last resort, it only takes place to satisfy the Edge feature. Even if it exists, it demands the Spec position of the functional head to be filled. Moreover, Chomsky' (2005) operation Agree is in agreement with the Economy Principle because uninterpretable features are valued and deleted in situ. One more advantage of the Agree Theory is that it can present a unified account of word order variation in SA.

## B. Recent Development in Minimalist Analysis

### A). Phases

It can be observed that the recent minimalist developments in Chomsky's (2004, 2005) Phase Theory is a visible departure from the earlier minimalist analysis of Chomsky (1993, 1995). In "On Phases", Chomsky (2005) proposes that the phase is a syntactic unit of the computational system and that the head of this phase is responsible for initiating syntactic operations. In the Phase Theory, Chomsky (2005) sees that the syntactic derivation proceeds further phase by phase and that spell-out applies cyclically. This entails that uninterpretable features are valued and deleted at the phase level. That is, once the derivation of the phase gets completed, the phase is transferred immediately to the LF and PF components.

When the phase is complete its domain becomes inaccessible to any further syntactic operation. On the other hand, the head and the left peripheral edge can get involved in a further operation; the phases derived must obey the Cyclicity Condition (referred to as the Phase Impenetrability Condition (PIC) by Chomsky 2000), illustrated in (7).

7. "In Phase  $\alpha$  with head H, the domain of H is not accessible to operations outside  $\alpha$ , only H and its edge are accessible to such operations." (Chomsky, 2000, p. 108)

Given PIC in (7), Chomsky (2000) illustrates that "cycle is so strict that operations cannot look into a phase  $\alpha$  below its head H. H itself must be visible for selection and head-movement, hence its SPECs as well" (p. 108).

Nevertheless, Chomsky postulates that CP and vP are phases, whereas TP is not. It should be noted that in subsequent work, Chomsky refines the vP phase to v\*P phase, for the reason that "v\*" is the functional head associated with full argument structure, transitive and experiencer constructions" (Chomsky, 2005, p. 10). Chomsky indicates that the morpho-syntactic property of phases is that their heads contain  $\phi$ -features. Chomsky (2005) assumes that TP is not a phase because its head does not have tense or  $\phi$ -features.

### B). Feature Inheritance

Unlike Chomsky (1995, 2000, 2001), Chomsky (2005) argues that the head T lacks  $\phi$ -features and tense feature in the lexicon. On this basis, Chomsky assumes that TP cannot be a phase. Moreover, Chomsky indicates that TP is a derivative phase for it inherits features from the head C of CP. If T is selected by C, it projects these features, if not then "it is a raising [...] infinitival, lacking  $\phi$ -features" (Chomsky, 2005, p. 10). Once T is probing down for a matching goal, it is valuing the features of C. Put differently, C and T constitute a complex probe which agrees with the matching goal. Chomsky (2005) argues that the matching goal can stay in its position with its uninterpretable features valued and deleted via the Agree relation, "or it can raise as far as SPEC-T, at which point it is inactivated, with all the features valued, and cannot raise further to SPEC-C" (p. 10).

Furthermore, the relation between the v\* head of v\*P, and the V head of its complements, resembles the relation between the C head of CP and the head T of TP. v\* of v\*P transmits its features to V. In this context, Chomsky (2005) argues that the phase heads C and v\* have two types of features: Agree features ( $\phi$ -features) and the Edge features, beside a tense feature on C. Being the heads of complements, T and V inherit the Agree features from C and v\*. Chomsky (2005) stresses that the Edge feature triggers movement to the SPEC of the phase head. Besides, Chomsky distinguishes between A-movement and A'-movement; he assumes that the SPEC of CP and the extra of SPEC of v\*P are A'-positions.

## IV. DERIVATIONAL OPERATIONS IN SA

It has been assumed in the existing literature (cf. Rizzi, 1997; Chomsky, 2005; and Fassi Fehri, 2005, among others) that VSO and SVO orders are determined by the head C of CP. It is in Rizzi's (1997) analysis that CP is split into a number of projections such as Force Phrase, Finite Phrase, Topic Phrase and Focus Phrase. Rizzi (1997) argues that Topic Phrase and Focus Phrase can be projected between Force Phrase and Finite Phrase. Moreover, based on Chomsky's (2005) analysis, I assume that the Edge feature of the head C attracts topics from lower positions in SA. On the other hand, I do not adopt Chomsky's (2005) proposal that topics should raise to Spec-CP, but rather I argue that the preverbal topics in SA have to raise to the specifier position of Topic Phrase (TopP). Given this, I adopt Rizzi's (1997) Split-CP analysis and argue that the preverbal topic in SA can be raised to Spec-TopP which occupies the position between TP and CP. Let us represent this proposal in (8) to illustrate the point in SA.

8.

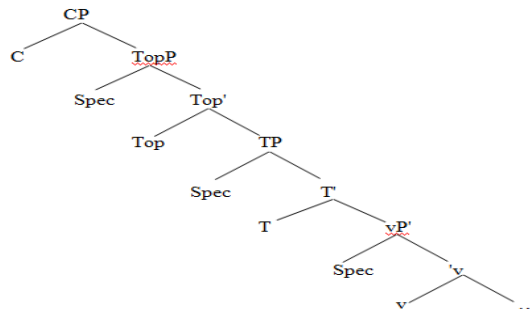

A closer look at Chomsky's (2005) analysis reveals that Chomsky distinguishes between A-movement and A'-movement. He indicates that Spec of CP and the outer Spec of vP are A'-positions. He argues that A'-movement is motivated by the phase head. The edge feature of the phase head initiates A'-movement on condition that the A'-raised constituent has not undergone any A-movement. If I follow Chomsky's assumption then it entails that the edge feature of C is not able to initiate A'-movement from Spec of TP which is considered to be the legitimate landing site of A-movement. Chomsky sees that A'-movement and A-movement are motivated by the phase head. On the other hand, he states that A-movement is different from A'-movement in that the former is not initiated directly by the edge feature of the phase head. He stresses that such movement is motivated indirectly by the C features which the head T inherits in the course of the derivation. According to Chomsky, such features motivate the subject to raise from Spec-vP to spec-TP.

Furthermore, following Rizzi (1997) Split-CP analysis, Chomsky's (2005) disassociation between  $\phi$ -features of C on T and the edge feature of C, and in line with Musabhein (2008), I assume that in SA the head C transmits the edge feature in a way similar to that of  $\phi$ -features. I argue along with Musabhein (2008) that as  $\phi$ -features are inherited by T, the edge feature is inherited by the head Top of TopP. That is, C transmits the edge feature to Top and  $\phi$ -features to T of TP. This can be demonstrated in (9).

9.

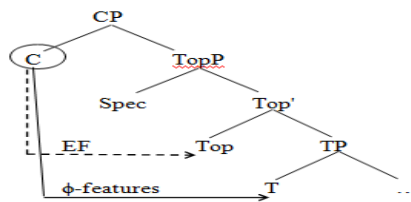

As shown in (9), I assume that in SA the head Top inherits the edge feature from C. This means that the preverbal topic in SVO structure in SA can be raised from the Spec of vP to the Spec position of TopP. In other words, this proposal entails that the topicalised constituent does not raise from Spec-vP to Spec-CP as assumed in Chomsky (2005) but rather from Spec-vP to Spec-TopP to receive topicalisation.

## V. THE DERIVATION OF VSO AND SVO WORD ORDERS IN SA

This section explores how VSO and SVO word orders are derived morph-syntactically in SA and in turn proposes two clause structures of these word orders on the basis of Chomsky's (2005) feature-based-inheritance framework. Besides, I adopt Rizzi' (1997) Split-CP analysis and suggest some modification of Chomsky's (2005) clause structure with regard to the SVO order derivation in SA; a Topic Phrase (TopP) projection is projected between CP and TP in the SA clause structure in order to account for position of the topicalised subject.

### A. The Morpho-syntactic Derivation of VSO Order in SA

It should be stated that the most commonly used word orders in SA are VSO and SVO; the former (i.e. VSO) is treated as the unmarked order by the Arab and Western linguists while the latter is the marked order. Furthermore, given Chomsky's (2005) minimalist analysis, I show how VSO in SA is obtained in minimalist syntax. The unmarked VSO structure is derived by movement of the lexical verb from V to the functional head v (i.e. the light verb) and then to the functional head T. The structural relations between the functional head v (the probe) and the object (the goal), from one hand, and the functional head T (the probe) and the subject (the goal), on the other, illustrate that the Agree relation can apply in the syntax. It should be pointed out that in Chomsky's (2005) Feature Inheritance model, the Agree operation operates downward for the sake of feature valuation purposes. As a consequence, the unvalued uninterpretable features of the functional heads (v and T) and the nominals (object and subject) are valued and hence deleted under the Agree relation.

On the other hand, building on Chomsky's (2005) minimalist framework, I argue that the subject DP in SA has to stay in situ, that is, it has to remain in Spec-vP. But why does the subject DP in SA remain in situ? The reason behind this can be attributed to the fact that the head C in VSO in SA does not have an edge feature which entails that no movement of any constituent is needed. Let us demonstrate in (10) the derivational process of VSO order in SA.

10.

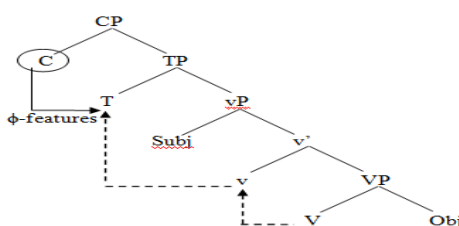

As shown in (10), T inherits  $\phi$ -features from the head C of CP. It also shows clearly the verb movement; the functional head V moves to the light functional head v and then to the functional head T in order to ensure that all uninterpretable features are valued and eliminated.

*B. The Morpho-syntactic Derivation of SVO Order in SA*

The morpho-syntactic derivation of SVO order in SA is obtained in the same way as that of VSO. However, the only difference in the derivation between VSO and SVO in SA is that a further syntactic operation applies in the derivation of SVO; the operation Move (or what Chomsky (2005) calls Internal Merge) takes the subject DP from Spec-vP to a preverbal position where it is topicalised; it occupies Spec-TopP. What happens in the derivation of SVO in SA is that the verb raises from the functional head V to the light functional head v; the latter (being the phase head and the probe) searches for a matching head; it probes down and agrees with the object DP, the goal. The next step is that the verb moves to the functional head T. Being the probe, T, which has already inherited  $\phi$ -features from the functional head C (the phase head) of CP, agrees with the subject DP, since it is the matching goal it c-commands. As a result, T (the probe) agrees with the subject (the goal) in Spec-vP.

Moreover, I argue along with Musabhein (2008) that the head T does not inherit a feature which initiates subject raising, but rather, the subject movement from Spec-vP to a preverbal position is initiated immediately from the head C by the head Top of TopP; this means that preverbal DP is raised to Spec-TopP. Furthermore, Chomsky assumes that topic movement is initiated by the edge feature of the head C. I argue that the presence of the feature on the head Top of TopP motivates the topicalised subject in SVO order in SA to move from Spec-vP to Spec-TopP. Let us illustrate the point in (11).

11.

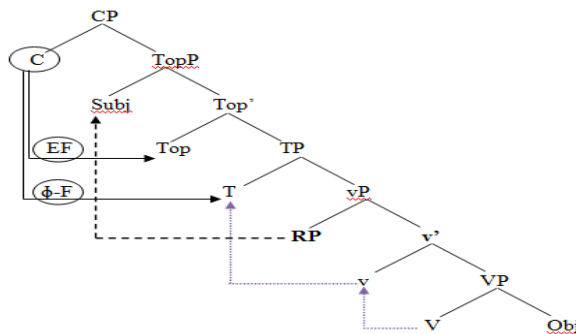

(11) illustrates that the verb moves from V to v and then from v to T. (11) also shows that the subject moves from Spec-vP to Spec-TopP and as a result the subject movement leaves behind a resumptive pronoun (RP) in Spec-vP.



Besides, (11) demonstrates that the edge feature (EF) of Top is inherited from C and  $\phi$ -features of T are also inherited from C. According to Rizzi's (1997) Split-CP analysis, the two projections (TopP and TP) in (11) above are contained within the CP layer. Furthermore, building on Chomsky's (2001, 2005) analysis On Phases and Feature Inheritance framework, TopP and TP projections are not phases. Consequently, the two heads of TopP and TP inherit their features from the head C of the CP phase. As the representation in (11) shows, T inherits  $\phi$ -features and agrees with the postverbal subject in Spec-vP and the head Top inherits the edge feature from C as well. It is the edge, inherited from C, which triggers subject movement to Spec-TopP.

### C. Agreement in VSO Order in SA: Partial Agreement

In this section I explore agreement in VSO order in SA and show how it can be accounted for within Chomsky's (2005) feature-based-inheritance model. It is VSO order which is considered to be the unmarked order in SA syntax. In VSO order the sentence begins with the verb followed immediately by the verb. Furthermore, it can be observed in Standard Arabic syntax that it is the position of the subject in the sentence which determines the type of agreement with the verb; whether the agreement on the verb is full or partial in terms of  $\phi$ -features (i.e. person, gender and number). Let us illustrate the point in (12).

- 12.a qara?- **a**      zayd-un      riwaayat-an  
 read      Zayd.Nom      novel.Acc  
 'Zayd read a novel.'
- b. qara?a -**t**      hind-un      riwaayat-an  
 read.f.marker      Hind.Nom      novel.Acc  
 'Hind read a novel.'
- c. \*qara? -**a**      hind-un      riwaayat-an  
 read.f.marker      Hind.Nom      novel.Acc  
 'Hind read a novel.'
- d. qara?- **a**      al-Taalibaani      riwaayat-an  
 read      (two male)students.dual.m.Nom      novel.Acc  
 'Both (male) students read a novel.'
- e. \*qara?- **at**      al-Taalibaani      riwaayat-an  
 read      (two male)students.dual.m.Nom      novel.Acc  
 'Both (male) students read a novel.'
- f. qara?a -**t**      al-Taaliba-taani      riwaayat-an  
 read.f.marker      (two female)students.dual.f.Nom      novel.Acc  
 'Both (female) students read a novel.'
- g. qara?- **a**      al-Tullaab-u      riwaayat-an  
 read      students.m.pl.Nom      novel.Acc  
 'The (male) students read a novel.'
- h. \*qara?- **at**      al-Tullaab-u      riwaayat-an  
 read      students.m.pl.Nom      novel.Acc  
 'The (male) students read a novel.'
- i. qara?a -**t**      al-Taalib-aat-u      riwaayat-an  
 read.f.marker      students.f.pl.Nom      novel.Acc  
 'The (female) students read a novel.'

All the sentences in (12) above, which illustrate singular (12a) and (12b), dual (12d) and (12f) and plural (12g), (12i), show that in VSO order the verb agrees with its subject only in gender, but not in number. That is, the verb exhibits gender agreement (i.e. partial agreement) with the subject DP, if it is a full DP. This further stresses that in VSO the verb is impoverished and therefore shows only gender agreement with the postverbal subject DP; no person and number agreement is realized in the syntax. Moreover, when the postverbal subject DP is feminine (as shown in the gender suffix marker -t in (12b), (12f), and (12i)), the gender agreement is morphologically marked on the verb. However, (12a), (12d), and (12g) show that gender agreement is not morphologically realized when the masculine agreement morpheme is null in SA. On the other hand, the sentences in (12c), (12e), and (12h) are ungrammatical because there is no gender agreement between the verb and the subject; the gender marker suffixed to the verb shows no agreement with its postverbal DP.

Furthermore, since SA is a rich inflectional language with a rich agreement system, the subject of the sentence can be either covert (i.e. null) or a pronominal clitic attached to the verb. This can be demonstrated below. The examples in (12) are reproduced in (13) for further illustration.

- 13.a qara?- **a**      *pro*      riwaayat-an  
 read      novel.Acc  
 'He read a novel.'
- b. qara?a -**t**      *pro*      riwaayat-an  
 read.f.sg      novel.Acc  
 'She read a novel.'



- c. qara?- **aa**                      riwaayat-an  
 read.m.dual.Nom      novel.Acc  
 'Both (male) students read a novel.'
- d. qara?a **-taa**                      riwaayat-an  
 read.f.dual.Nom      novel.Acc  
 'Both (female) students read a novel.'
- e. qara?- **uu**                      riwaayat-an  
 read.m.pl.Nom      novel.Acc  
 'The (male) students read a novel.'
- f. qara?a **-na**                      riwaayat-an  
 read-f.pl.Nom      novel.Acc  
 'The (female) students read a novel.'

(13) shows that in VSO the postverbal subject may not be necessarily a full DP; it can also be a null *pro* where its identity can be recovered from the verb morphology, as shown in (13a and 13b) above. Besides, it can appear in the form of a pronominal clitic suffixed to the verb, as illustrated in (13c, 13d, 13e, and 13f). What is happening in (12) and (13) above shows clearly that SA has a rich agreement paradigm.

Now let us examine how the Arabic data interact with Chomsky's (2005) feature-based-inheritance analysis. The objective is to find out whether the feature inheritance framework can be applicable in SA syntax. Let us take the example in (12a) to be reproduced in (14) in order to illustrate the point clearly.

- 14.a qara?- **a**      zayd-un      riwaayat-an  
 read      Zayd.Nom      novel.Acc  
 'Zayd read a novel.'
- b.

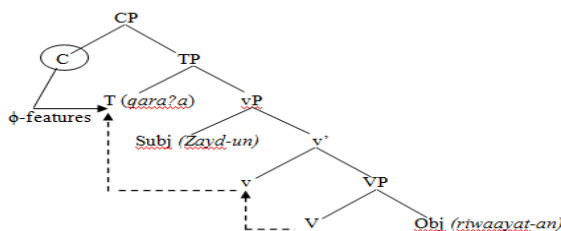

The syntactic representation in (14b) shows that the unmarked VSO order in SA is derived by movement of the lexical V to the higher functional heads v and T, respectively, as illustrated in the dotted arrows. The solid arrow, however, shows that  $\phi$ -features of T are inherited from C, the latter being the probe and the head of CP. However, following Chomsky's (2005) analysis, I assume that in VSO order in SA the postverbal subject DP *Zayd-un* does not raise from its original position of Spec-vP because it has its features valued and deleted under the Agree relation with the c-commanding T. The justification as to why the subject has to remain in situ in Spec-vP in SA can be attributed to the fact that the head C in VSO order does not have an edge feature. This means that no movement of any element is required here.

Furthermore, I argue that agreement on the verb *qara?a* 'read', which is the outcome of the Agree relation, is achieved under the probe-goal relation. It is the Agree relation which establishes the relation between the head T (as the probe) and the subject (as the goal). As the Agree relation operates downward, it entails that the head T agrees with the subject DP it c-commands in Spec-vP. As a result, all unvalued uninterpretable features of the functional heads (C, T, v, and V) and nominals (the subject and object) are valued and hence eliminated under the Agree relation in the course of the derivation.

Besides, what is interesting in Chomsky's (2005) analysis is that a convergent derivation of VSO order in SA can be derived as an Agree relation can be established regardless of the position occupied by the subject. Building on Chomsky's (2005) On Phases, C is the phase head which is the source of all features that motivate the Agree relation to operate in the syntax. Since C has all features (i.e.  $\phi$ -features and Edge feature), T inherits these features from C, being the phase head. In this connection, Chomsky (2005) states that when "C-T agrees with the goal DP, the latter can remain in situ [i.e. SPEC vP] under long-distance agree, with all interpretable features valued; or it can raise as far as SPEC-T, at which point it is inactivated, with all features valued" (P.10). This suggests that the domain of the probe C (the phase head of CP) extends from the Spec-TP to -vP.

*D. Agreement in SVO Order in SA: Full Agreement*

In this section, I attempt to examine how SVO order is derived in SA. I also propose a clause structure of the derived SVO order in SA based on Chomsky's (2005) feature-based-inheritance framework. Further, I suggest some modification of Chomsky's (2005) clause structure and in turn adopt Rizzi' (1997) Split-CP analysis, the latter projects

TopP between CP and TP. The objective is to provide a unified account of the position of the preverbal subject in SVO order in SA. To illustrate the point let us examine the examples in (15).

- 15a. al-walad -u      ?akal-**a**      al-tuffaah- a  
 the.boy.nom      ate.m.sg      the.apples.Acc  
 'The boy ate the apples.'
- b. al-bint -u      ?akal-**a-t**      al-tuffaah- a  
 the.girl.nom      ate.f.sg      the.apples.Acc  
 'The girl ate the apples.'
- c. al-walad -**aani**      ?akal-**aa**      al-tuffaah- a  
 the.(two)boys.m.dual.nom      ate.m.sg      the.apples.Acc  
 'The (two) boys ate the apples.'
- d. \*al-walad -**aani**      ?akal-**a**      al-tuffaah- a  
 the.(two)boys.m.dual.nom      ate.m.sg      the.apples.Acc  
 'The (two) boys ate the apples.'
- e. al-bint -**aani**      ?akal-**a-taa**      al-tuffaah- a  
 the.(two)girls.f.dual.nom      ate.f.sg      the.apples.Acc  
 'The (two) girls ate the apples.'
- f. al-?awlaad -**u**      ?akal-**uu**      al-tuffaah- a  
 the. boys.m.pl.nom      ate.m.pl      the.apples.Acc  
 'The boys ate the apples.'
- g. \*al-?awlaad -**u**      ?akal-**a**      al-tuffaah- a  
 the. boys.m.pl.nom      ate.m.pl      the.apples.Acc  
 'The boys ate the apples.'
- h. al-banaat -**u**      ?akal-**na**      al-tuffaah- a  
 the. girls.f.pl.nom      ate.f.pl      the.apples.Acc  
 'The girls ate the apples.'
- i. \*al-banaat -**u**      ?akal-**at**      al-tuffaah- a  
 the. girls.f.pl.nom      ate.f.pl      the.apples.Acc  
 'The girls ate the apples.'

A closer look at the sentences in (15) reveals that SVO order in SA shows full agreement between the subject and the verb in terms of  $\phi$ -features (i.e. person, number and gender). The ungrammaticality of (15d), (15g), and (15e) can be attributed to the fact that the verbs do not agree with their respective subject DPs in all  $\phi$ -features; the subject-verb agreement is not full. This provides support that in SVO order in SA partial agreement is not grammatically accepted in SA syntax.

On the other hand, the questions arise are: how do we account for the preverbal subject in SVO structures in SA? How do we treat the pronominal clitic suffixed to the verb? How can SVO order be represented in the proposed clause structure in SA? Before answering these questions, I review what has been done by the Arab and Western linguists with regard to SVO analysis. The previous analyses on agreement and word order in SA have revealed that there are two major views in this regard. The first view (advocated in Ibn Hisham (1211) and Hassan (1961)) indicates that the subject cannot precede the verb. They treat the preverbal subject DP as a topic rather than a subject; the comment is a full verbal sentence which as a postverbal pronominal subject shows up as a clitic on the verb. They stress that the postverbal pronominal subject is associated with the preverbal subject. The second view is adopted by modern linguists (Mohammad, 1990, 2000; Fassi Fehri, 1993, 2004; Shlonsky, 1997; Aoun and Benmamoun, 1999; Benmamoun, 2000b; and Soltan, 2006, among others), who treat the pronominal clitic on the verb as a number marker.

Having examined the two views demonstrated above, let us see how the Arabic data interact with Chomsky's (2005) minimalist analysis. If I claim that the pronominal clitic on the verb can be treated as a number marker, then the agreement asymmetry in SA remains unaccounted for especially if I stick to the Agree theory in which the Agree relation applies one time between a probe and its c-commanding goal. Besides, if I claim that the head T agrees with the postverbal subject in a probe-goal relation and the subject raises from Spec-vP to a preverbal position in Spec-TP, then the head T will not be able to have a further Agree relation with the preverbal subject.

Moreover, much controversy has been observed among the Arab and Western authors concerning whether the preverbal subject in SVO order in SA is merged externally or moved from Spec-vP. In this context, there are two accounts in the existing literature on agreement in SA. The first account views the preverbal NP as a subject (Mohammad, 1990, 2000; Demirdache, 1991; and Benmamoun and Lorimor, 2006). The second account treats the preverbal subject as a broad subject (Doron and Heycock, 1999). It is the second account which sees the preverbal subject as a topic (Plunkett, 1993; Akkal, 1996; and Ouhalla, 1997) or a focus (Ouhalla, 1997).

Almost all linguists who treat the preverbal subject as a subject argue that this subject moves from the original position of Spec-vP to a higher position of Spec-TP. Some of them even assume that SVO in SA is derived by movement of the subject to preverbal position (Aoun et al, 1994; and Mohammad, 2000). On the other hand, Fassi Fehri (1993) distinguishes between the subject and topic in SA. Fassi Fehri observes that when the preverbal NP is a topic, it

has to occupy a position with the CP layer; a topic projection has to be higher than that of TP projection. But when the preverbal subject is a subject, it can best be positioned in Spec of TP.

It should be noted that the traditional Arab grammarians treated the preverbal subject noun phrase as a topic in their syntactic analyses. In this connection, Plunkett (1993) indicates that the preverbal subject NPs in (16) are topics.

- 16a. aT-Tulaab-u            yadrus-uuna  
       the.students.Nom    study.3s.p  
       'The students, (they) are studying.'
  - b. aT-Tulaab-u            uHibu-hum  
       the.students.Nom    like.1s.them  
       'The students, I like them.'
- (Plunkett, 1993, p. 241)

Plunkett sees that both the topics in (16) are associated with the resumptive pronouns. Plunkett states that the resumptive pronoun in (16a) is null while it is overt in (16b); the latter is a pronominal clitic suffixed to the verb.

On the other hand, Ouhalla (1997) points out that there are two types of preverbal NPs: one can be a topic, as in (17a) and the other a focus, as in (17b) below.

- 17a. al-riwaayat-u    a'llafat-haa    zaynab-u  
       the.noverl.Nom    wrote.3fs.it    Zaynab.Nom  
       '(As for) the novel, Zaynb wrote it.'
  - b. RIWAAYAT-AN    a'llafat    zaynab-u  
       novel.Acc            wrote.3fs    Zaynab.Nom  
       'It was a novel that Zaynab wrote.'
- (Ouhalla, 1997, p. 12)

Ouhalla shows that topics are different from 'f-phrases' (=Focus Phrase) in the sense that the former carry nominative Case. Ouhalla (1991, 1997) observes that topics are base-generated in the preverbal position and are associated with a resumptive pronoun inside it. However, Muasbhein (2008) argues that Ouhalla is not precise with regard to the positions occupied by the topic.

It is obvious now that in VSO order there is no resumptive pronoun in the postverbal subject position. The problem is only with SVO order which has the preverbal subject associated with a resumptive pronoun in the postverbal subject position, which is treated as number marker by some Arab linguists.

Having reviewed the relevant analyses on the position of the preverbal subject in SVO order in SA, there is in a need, in this respect, to provide a satisfactorily unified account on the subject in question. What is different in the alternative analysis from the preceding accounts is that the former (i.e. the alternative analysis) is based on the latest version on Chomsky's (2005) On Phases and Feature Inheritance model; it offers a neat account on the subject under discussion. In this regard, following the traditional Arab grammarians' views, and building on Plunkett (1993) and Musabhein (2008), I argue that the preverbal subject NPs in SVO order in SA are topics, not subjects. Besides, I do not assume that the resumptive marker can be treated as a number marker, as advocated in Plunkett (1993), Benmamoun (2000a), and Soltan (2006), among others, but rather I treat it as a resumptive pronoun which is associated with a fronted NP. On the other hand, I do not adopt Chomsky's (2005) proposal that topics have to raise to Spec-CP, but rather I argue that the preverbal topics in SA must move to Spec-TopP. In this regard, I adopt Rizzi's (1997) Split-CP analysis and argue that the preverbal topic in SA should be raised to Spec-TopP, a position between TP and CP. Besides, I suggest a modification of Chomsky's (2005) clause structure where TopP projection is projected between CP and TP in order to explain the position of the preverbal topic in SVO in SA. Let us now illustrate the point, where the preceding sentence in (15) has been reproduced in (18) for the sake of more illustration.

- 18a. al-walad -u    ?akal-a    al-tuffaah- a  
       the.boy.nom    ate.m.sg    the.apples.Acc  
       'The boy ate the apples.'
- b.

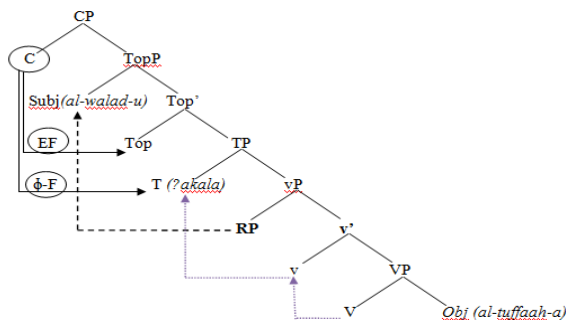

From the sentence in (18), it is obvious that the lexical verb ?akala 'ate' moves higher from the functional head V position to the functional light head v which in turn agrees with the object. Then v moves higher to the functional head T. Furthermore, phi-features on T initiate an Agree relation with the subject in Spec-vP. The subject DP al-waladu 'the

boy' moves from Spec-vP to Spec-TopP. In this connection, I assume that since the edge feature of the head C of the CP phase is inherited by the Top head, the topicalised elements in Standard Arabic are raised from lower positions to the specifier position of TopP, not the specifier of CP, as assumed in Chomsky (2005). The subject movement in (18) leaves behind a resumptive pronoun (RP) in the specifier position of vP. Besides, the SA clause structure in (18) above shows that the edge feature (EF) of the head Top of TopP is inherited from C and  $\phi$ -features of T are also inherited from C in the same manner. Building on Rizzi's (1997) Split-CP account, the projections TopP and TP in the clause structure in (18) above are projected below the CP layer. On the basis of Chomsky's (2001, 2005) minimalist assumptions, I assume that TopP and TP are not phases in SA. As a result, their heads Top and T inherit their features from the head C of the CP phase. Consequently, T inherits  $\phi$ -features and agrees with the postverbal subject in Spec-vP and Top inherits the edge feature from C. The inherited edge feature from C motivates the subject DP in (18) to move to Spec-TopP for feature valuation. Hence all unvalued uninterpretable features are valued and deleted in the syntax, thus deriving a convergent SVO structure in SA.

## VI. CONCLUSION

The study explored agreement in SA and pointed out how VSO and SVO orders are derived on the basis of Chomsky's (2005) feature inheritance approach; it aimed at presenting a satisfactory analysis on the subject under discussion. It suggested a morpho-syntactic proposal which explained how VSO and SVO appeared on a clause structure of SA and illustrated the difference in derivation between VSO and SVO. Furthermore, it presented an alternative analysis based on Chomsky' (2005) feature-based-inheritance model; it proposed that because the edge feature of the head C of the CP phase is inherited by the Top head, the topicalised elements in Standard Arabic are raised from lower positions to the specifier position of TopP in SVO order, not the specifier of CP, as assumed in Chomsky (2005). Besides, I adopted Rizzi's (1997) Split-CP analysis and proposed a modification of Chomsky's (2005) clause structure in order to account for the topicalised subject in SVO in SA.

Moreover, I pointed out that whether the subject, i.e. the goal with which C agrees, in Spec-vP in VSO or in Spec-TopP in SVO, the Agree operation applies, hence all unvalued uninterpretable features are valued and deleted by matching them with their valued counterparts. Besides, the paper pointed out that in SA the features of T in VSO and the features of T and Top in SVO are inherited from C, the head of CP. In addition, in both VSO and SVO, the lexical V moves to v, and in turn agrees with the object. Then v raises higher to T. Furthermore,  $\phi$ -features on T initiate an Agree relation with the subject in Spec-vP. The difference between VSO and SVO is that the subject in VSO remains in situ while it moves from Spec-vP to Spec-TopP via TP in SVO. This explains how SVO and VSO are derived in minimalist syntax.

## REFERENCES

- [1] Akkal, A. (1996). How SVO is SVO in Standard Arabic. In Fassi-Fehri, A. (ed.) *Linguistique comparee et langues au Maroc*. Rabat: Universite Mohamed V: Publications de la Faculte des Lettres et des Sciences Humaines. 101-27.
- [2] Al-Horais, N. (2009). A minimalist approach to agreement in Arabic. *Newcastle working papers in linguistics*. 15:1-22.
- [3] Aoun J., Benmamoun E. & Sportiche, D. (1994). Agreement, conjunction and word order in some varieties of Arabic. *Linguistic Inquiry* 25: 195-220
- [4] Aoun, J. & Benmamoun, E. (1999). Gapping, PF merger and patterns of partial agreement. In Lappin, S. & E. Benmamoun (eds.) *Fragments: Studies in Ellipsis and Gapping*. New York Oxford University Press. 175-92.
- [5] Bahloul, M. & Harbert, W. (2002). Postverbal subjects in Arabic in Ouhalla J e Shlonsky Ur, *Themes in Arabic and Hebrew syntax. Studies in Natural Language and Linguistic Theory*. 45-70.
- [6] Benmamoun, E. (1992). Functional and inflectional morphology: problems of projection, representation and derivation. Doctoral dissertation. USC, Los Angeles. 277
- [7] Benmamoun, E. (2000a). Agreement asymmetries and the PF interface. In Lecarme, J., Lowenstamm & U. Shlonsky (ed.) *Research in Afroasiatic Grammar*. Amsterdam: John Benjamins. 23-40.
- [8] Benmamoun, E. (2000b). The feature structure of functional categories: a comparative study of Arabic dialects. New York; Oxford: Oxford University Press.
- [9] Benmamoun, E. & Lorimor, H. (2006). Featureless expressions: when morphophonological markers are absent. *Linguistic Inquiry* 37: 1-23.
- [10] Bolotin, N. (1995). Arabic and parametric VSO agreement. In Eid, M. (ed.) *Perspectives on Arabic linguistics VII: papers from the seventh annual Symposium on Arabic Linguistics*. Amsterdam: John Benjamins. 7-27.
- [11] Chomsky, N. (1981). Lectures on government and binding. Dordrecht, Holland; Cinnaminson, N.J.: Foris Publications.
- [12] Chomsky, N. (1986a). Barriers. Cambridge, Mass; London: MIT Press.
- [13] Chomsky, N. (1991). Some notes on the economy of derivation and representation. In Freidin, R. (ed.) *Principles and Parameters in comparative grammar*. Cambridge: MIT Press. 417-454.
- [14] Chomsky, N. (1993). A minimalist program for linguistic theory. In Keyser, K. H. a. S. J. (ed.) *The View from Building 20: Essays in Linguistics in Honor of Sylvain Bromberger*. Cambridge, MA: MIT Press. 1-52.
- [15] Chomsky, N. (1995). The minimalist program. Cambridge, Mass: MIT Press.
- [16] Chomsky, N. (2000). Minimalist inquiries: the framework. In Lasnik, H., R. Martin, D. Michaels & J. Uriagereka (eds.) *Step by step. essays on minimalist syntax in honor of Howard Lasnik*. Cambridge. Mass: MIT Press.

- [17] Chomsky, N. (2001). Derivation by phase. In Kenstowicz, M. (ed.) *Ken Hale. A life in language*. Cambridge, Mass: MIT Press. 1-52.
- [18] Chomsky, N. (2004). Beyond explanatory adequacy. In Belletti, A. (ed.) *Structures and beyond, the cartography of syntactic structures, Vol. 3*. Oxford: Oxford University Press. 104-31.
- [19] Chomsky, N. (2005). On phases. Ms. MIT.
- [20] Chomsky, N. & Lasnik, H. (1993). The theory of principles and parameters. In Jacobs, J., A. v. Stechow, W. Stempfled & T. Vennemann (eds.) *Syntax: An international handbook of contemporary research*. Berlin: Walter de Gruyter. 506-69.
- [21] Corbett, G. G. (2006). Agreement. Cambridge: Cambridge University Press.
- [22] Demirdache, H. (1991). Resumptive chains in restrictive relatives, appositives, and dislocation structures. Doctoral dissertation. MIT.
- [23] Doron, E. & Heycock, C. (1999). Filling and licensing multiple specifiers. In Adger, D., S. Pintzuk, B. Plunkett & G. Tsoulas (eds.) *Specifiers*. Oxford: Oxford University Press. 69-89.
- [24] Fasih, A. (2012). The syntax of questions in Modern Standard Arabic: A minimalist perspective. London: Amazon.
- [25] Fasih, A. (2015). Wh-questions in Hodeidi Arabic: a phase-based approach. *Theory and Practice in Language Studies* 5,(4), 773-783.
- [26] Fassi Ferri, A. (1993) Issue in the structure of Arabic clauses and words. Dordrecht: Kluwer
- [27] Fassi Fehri, A. (2004). Temporal/Aspectual interaction and variation across Arabic heights. In Gueron, J. & J. Lecarme (eds.) *The syntax of time*. Cambridge: MIT Press. 235-57.
- [28] Fassi Fehri, A. (2005). The Arabic case for a CP phase. Ms. Mohammad V University. Rabat.
- [29] Franck, J., Lassi, G., Frauenfelder, U., & Rizzi, L (2006). Agreement and movement: a syntactic analysis of attraction. *Cognition* 101, 173-216.
- [30] Harbert, W. & Bahloul, M. (2002). Post verbal subjects in Arabic and the theory of agreement. In Ouhalla, J. & U. Shlonsky (eds.) *Themes in Arabic and Hebrew syntax*. Dordrecht: Kluwer. 45-70.
- [31] Hassan, A. (1961). an-nahwal-wafi. Cairo: dar al-ma'araef.
- [32] Holmberg, A. (2008). Null subject parameters. Ms., Newcastle University. [To appear in Biberauer, T., A. Holmberg, I. Roberts, and M. Sheehan. *Parametric variation: null subjects in minimalist theory*. Cambridge: Cambridge University Press].
- [33] Ibn Hisham, A. (1211). *Qatr Al-Nada wa Ballu Al-Sada [Dewdrops]*. Beirut: Al-Maktaba Alcasriyya.
- [34] Kayne, R. (1989). Facets of Romance past participle agreement. In Beninca, P. (ed.) *Dialect variation and the theory of grammar*. Dordrecht: Foris. 85-103.
- [35] Koopman, H. & Sportiche, D. (1991). The position of subjects. *Lingua* 85: 211-58.
- [36] Mahfoudhi, A. (2002). Agreement lost, agreement regained: a minimalist account of word order and agreement variation in Arabic. *California Linguistic Notes* 27: 1-28.
- [37] Mohammad, M. A. (1990). The problem of subject-verb agreement in Arabic: towards a solution. In Eid, M. (ed.) *Perspectives on Arabic linguistics I: papers from the first annual symposium on Arabic linguistics*. Amsterdam: John Benjamins. 95-125.
- [38] Mohammad, M. A. (2000). Word order, agreement, and pronominalization in Standard and Palestinian Arabic. Amsterdam: Benjamins.
- [39] Musabhien, M. (2008). Case, agreement, and movement in Arabic: a minimalist approach. Unpublished PhD dissertation, University of Newcastle, UK.
- [40] Ouhalla, J. (1991). Functional categories and parametric variation. London: Routledge.
- [41] Ouhalla, J. (1994). Introducing transformational grammar from rules to principles and parameters. London: Arnold.
- [42] Ouhalla, J. (1997). Remarks on focus in Standard Arabic. In Eid, M. & R. R. Ratcliffe (eds.) *Perspectives on Arabic linguistics X: papers from the Tenth Annual Symposium on Arabic Linguistics*. Amsterdam: John Benjamins. 9-45.
- [43] Ouhalla, J. (2005). Agreement features, agreement and antiagreement. *Natural Languages and Linguistic Theory* 23: 655-686
- [44] Plunkett, B. (1993). The position of subjects in Modern Standard Arabic. In Mushira, E. & C. Holes (eds.) *Perspectives on Arabic linguistics V: papers from the fifth annual symposium on Arabic linguistics*. Amsterdam: John Benjamins. 231-60.
- [45] Pollock, J.-Y. (1989). Verb movement, universal Grammar, and the structure of IP. *Linguistic Inquiry* 20: 365-424.
- [46] Rizzi, L. (1982). Issues in Italian syntax. Dordrecht: Foris.
- [47] Rizzi, L. (1997). The fine structure of the left periphery. In Haegeman, L. (ed.) *Elements of grammar*. Dordrecht: Kluwer: 281-337.
- [48] Shlonsky, U. (1997). Clause structure and word order in Hebrew and Arabic,' an essay in comparative Semitic syntax. New York: Oxford University Press.
- [49] Soltan, U. (2006). Standard Arabic subject-verb agreement asymmetry revisited in an Agree-based minimalist syntax. In Boeckx, C. (ed.) *Agreement systems*. 239-65.
- [50] Taraldsen, K. T. (1995). On agreement and nominative objects in Icelandic. In Haider, R, S. Olsen & S. Vikner (eds.) *Studies in comparative Germanic syntax*. Dordrecht: Kluwer. 307-27.



**Abdul-Hafeed Ali Fasih** holds an M.A, M.Phil, and Ph.D in Linguistics and is Associate Professor at the Department of English, Ibb University, where he was the Dean of Center of Languages. He taught linguistics in different universities in Yemen and abroad.

He published many papers on morpho-syntax and semantics of Standard Arabic and Arabic dialects in different international journals. He supervised many MA and PhD students in different universities. His interests focus on morph-syntax, semantics, phonetics & phonology, contrastive studies, and applied linguistics. He is currently teaching linguistics for BA and MA students at the Department of English, Najran University, Saudi Arabia.

Dr. Fasih is a member of different editorial and reviewer boards of international journals (USA, Canada, Finland, India, Malaysia, KSA, and Yemen).